



## EXPLORE THE WORLD

KAYAK / CANOE / STAND UP PADDLE



# 50 years of commitment for your leisure.

In 1973, François NEVEUX founds the Société d'Exploitation des Procédés Neveux, specialized at the time in the manufacture of concrete sanitation products. At the end of the 70's, Mr NEVEUX launches the Rotomoulage process in France, following the purchase of an American patent and creates several production sites in Lot & Garonne. He develops this process in the sanitation industry to produce septic tanks and derived products but also in many other fields, especially in the nautical industry. Over the years, several production plants were bought by its executives. After several phases of acquisitions and transmissions of companies, ROTOMOD becomes the new name of the company and specializes in the design and production of polyethylene canoes and kayaks but also of rotomolded products for subcontracting.



**ROTOMOD's** development of the canoe-kayak is mainly due to the introduction of Sit On Top (SOT) kayaks, unsinkable, self-draining and safe for the general public, on the French and European markets in the early 1990s.

In 2007, the company **ROTOMOD** takes control of the shareholding of its Ardèche colleague, the company **DAG**. In October 2012, the directors of **ROTOMOD** and **DAG**, in order to give themselves the structural means to assume the specific evolution of the market, decided to merge the two existing structures and thus create a better adapted common production and distribution pole. This resulted in the merger of **DAG** into **ROTOMOD** and thus constituted a new asset for success. **ROTOMOD** now has 2 brands: **RTM** and **DAG**.

With its 2 production sites in Bon Rencontre in Lot et Garonne (47) and St jean le Centenier in Ardèche (07), **ROTOMOD** offers a wide range of canoes and kayaks, regularly proposing new products and innovations. The company is also developing its activities in the design sector with the creation and production of furniture and lighting, following the purchase of the **BERGES** lighting company in October 2019.

It also welcomes projects from clients in a wide range of sectors such as agriculture, maritime and highway signage, water treatment, environmental protection, etc. In 50 years, **ROTOMOD** has been able to perpetuate its strategic choices and its investments. The company, which currently employs 80 people, is increasing its production capacity and is fully committed to an eco-responsible approach through self-management of polyethylene recycling.

**50 years is the age of maturity, the age at which it is time to take a quick look back so that the next 50 years will be in the continuity of development, innovation, to carry high the values of made in France, of eco-responsibility.**



# ROTOMOD French company Watersport specialist

**ROTOMOD** is a French SME, created in 1973 in Lot et Garonne. Over the years, the company has established itself in the agglomeration of Agen in Bon Encontre.

The main activity is the design, production and distribution of polyethylene canoes and kayaks. A part of the activity is dedicated to the production of various customers in the fields of agriculture, road and sea marking, food industry, design and lighting.

In 2007, ROTOMOD gets closer to the company DAG, another flagship of the industry linked to the canoe-kayak activity in France and in Europe. The Ardèche brand joined the Aquitaine company in 2012, its factory becoming the second production site of **SAS ROTOMOD**.

With its RTM and DAG brands, **ROTOMOD** offers a wide range of boats and accessories that meet the needs of professionals, clubs, and paddlers, regardless of their location and level.

**Photos :** SAFARAID - KAYAKTIVE MONTENEGRO - KAYAKMED SÈTE & HERVÉ LECLAIR - LYON EQUIPMENT LTD - STEVE ASHWORTH MEDIA - KAYA'KOOL - SEA KAYAK HALKIDIKI - KAYAKFERDIR - CANOË MÉJEAN - CIMES AVENTURE - ECOLE DE PAGAIE DU VELAY - CANOË MÉJEAN - ROSIÈRES BATEAUX CANOE ARDECHE - PATRICK RIVIERA DORDOGNE KAYAKMED SÈTE - KANOKAJAKI - CANOE EVASION - VIDRA VIZITURA - SEBASTIEN SPRING - STÉPHANE AMELINE - JONAS LEMORVAN - KAYAK EXPE - SPORT MIX - SEBASTIEN TESTER - FFCK - LOEUILLY CANOË KAYAK - ALLIANCE CANOË-KAYAK VAL DE LOIRE - ROMAIN BRUNEAU - PAN SARL - NICOLAS ROCHEREAU - MOULIN DE LA MALEINE - VILLECOURT





# MADE IN FRANCE

All our polyethylene canoes, kayaks and stand-up paddles are produced exclusively in France.

Our two factories employ a staff of 70, all of whom are dedicated to producing quality boats.



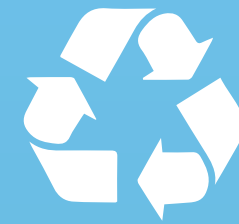

# ROTOMOD is committed to an eco-responsible policy.

Both production sites are equipped with a shredder, enabling the recycling of production surpluses.

**ROTOMOD** also collects end-of-life boats and other parts from its partners for recycling. The shredded material is then processed to re-create regenerated polyethylene powder, enabling the production of new units for the company's water treatment, construction, agricultural and other marine fittings sectors.

## Buy a kayak, canoe, SUP RTM or DAG

- + FRENCH KNOW-HOW, recognized in nearly 82 countries.
- + Acquire a product designed and manufactured in France.
- + Supporting the company's ECO-RESPONSIBLE commitment
- + Supporting ROTOMOD in polyethylene recycling.



### Acceptez nos (petites) imperfections !

Afin de réduire les émissions de CO2, ROTOMOD s'engage à accepter en fin de ligne de production des produits avec de petits défauts esthétiques n'altérant pas la sécurité, l'usage de ceux-ci. Si votre produit est visuellement imparfait, prenez conscience qu'il témoigne de notre eco-engagement.

### Accept our (small) imperfections !

In order to reduce CO2 emissions, ROTOMOD is committed to accepting products at the end of the production line with minor aesthetic defects that do not affect their safety or use. If your product is visually imperfect, be aware that it bears witness to our eco-commitment.



**ROTOMOD** acquies in 2019, 2020 and 2021 the **LABEL MORE, Mobilize to REcycle**, testifying to its commitment to the reprocessing of polyethylene and the integration in its production of regenerated products.

**ROTOMOD** proposes the RE-PE program, REcycling Polyethylene, to collect free of charge from our customers and users, boats and other polyethylene parts at the end of their life. The objective is to relieve the sites waiting for a solution and to ensure the recycling of these elements.

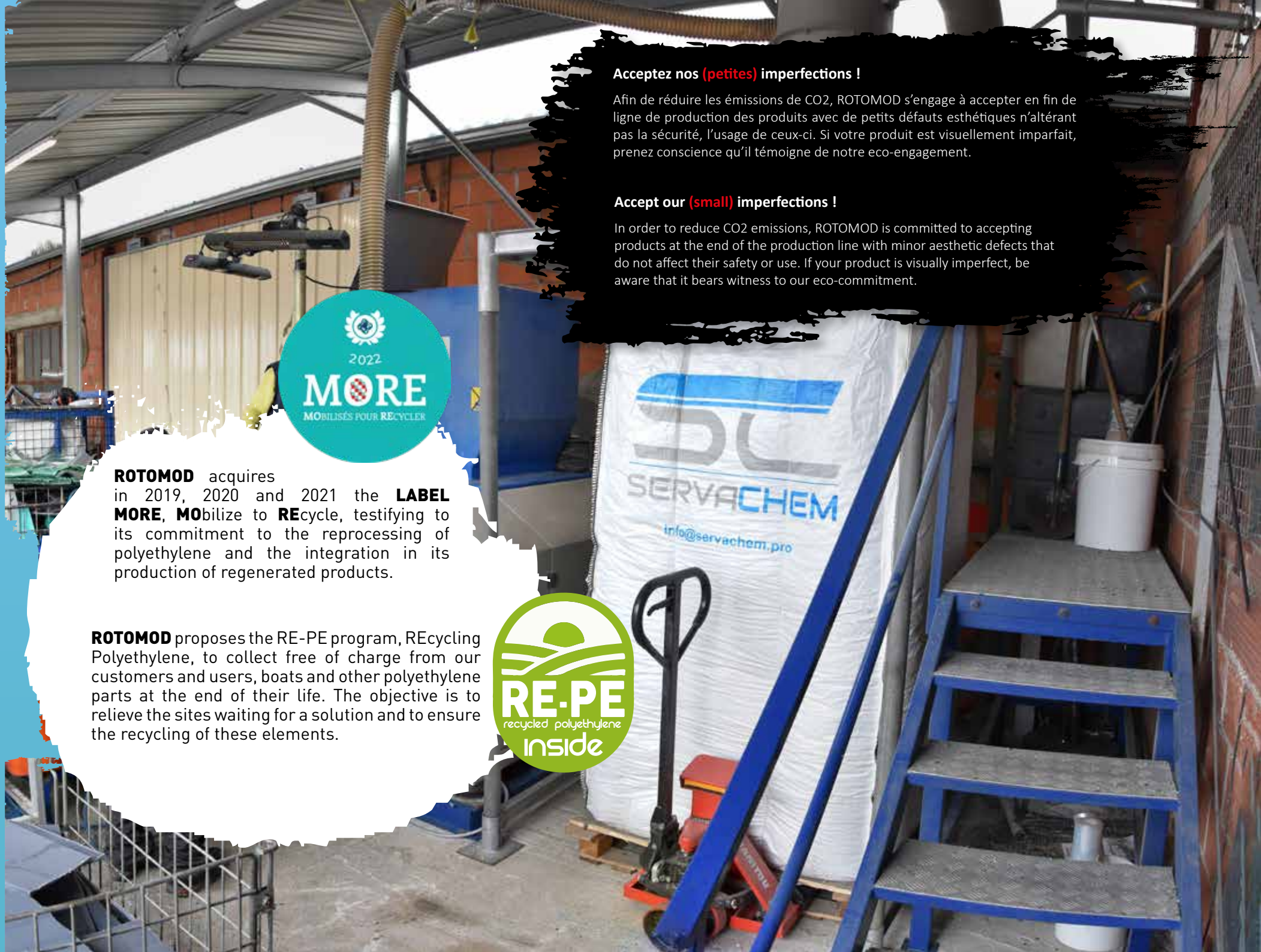

# LINE-UP.

SIT ON TOP



**MOJITO** SINGLE-SEATER SIT ON TOP  
In PACK version



**MAKAO COMFORT** SINGLE-SEATER SIT ON TOP  
Available in STD, PACK and PRO versions



**DUETTO COMFORT** MULTI-SEATER SIT ON TOP



**OCEAN DUO** MULTI-SEATER SIT ON TOP  
Available in STD or PACK versions



**OCEAN QUATRO** MULTI-SEATER SIT ON TOP



**DISCO+** SINGLE-SEATER SIT ON TOP



**MID-WAY** SINGLE-SEATER SIT ON TOP



**TEMPO** SINGLE-SEATER SIT ON TOP



**ABACO 3.60** SINGLE-SEATER SIT ON TOP



**SEAVIEW BOARD**



**HIRO** ANGLER KAYAK

ANGLER KAYAK



**RENTAL**



**MEZZO STANDARD** SIT IN MONOPLACE



**TAIKI EVO COMFORT** SINGLE-SEATER SIT ON TOP



**TANGO EVO COMFORT** SINGLE-SEATER SIT ON TOP



**OPTIMO EVO COMFORT** MULTI-SEATER SIT ON TOP



**TRIBAL PRO** MULTI-SEATER SIT ON TOP



**TARKA** MULTI-SEATER SIT ON TOP



**TANARGUE II** MULTI-SEATER SIT ON TOP

**TOURING**



**BRIO** SINGLE-SEATER TOURING



**CANADIA** MULTI-SEATER CANOE



**RIVIERA** MULTI-SEATER CANOE



**RIVIERA XL** MULTI-SEATER CANOE

**SEA KAYAK**



**MEZZO LUXE** SINGLE-SEATER SIT IN



**TIWOK EVO** SINGLE-SEATER SIT IN  
Available in LUXE or FUN versions



**MIWOK** SINGLE-SEATER SIT IN  
Available in HI-LUXE or HI-FUN versions



**YSAK** SINGLE-SEATER SIT IN  
Available in LUXE or HI-LUXE versions



**BIWOK EVO HI-LUXE** MULTI-SEATER SIT IN



**NELO 510** SINGLE-SEATER SURFSKI

**WHITEWATERS**



**PANAME** SINGLE-SEATER SIT IN



**SQUALY** SINGLE-SEATER SIT IN



**MAD'GIC** SINGLE-SEATER SIT IN



**STRIM JUNIOR** SINGLE-SEATER SIT IN



**STRIM SENIOR** SINGLE-SEATER SIT IN



**SX230** SINGLE-SEATER SIT ON TOP



**SX285** SINGLE-SEATER SIT ON TOP



**SPY 235** SINGLE-SEATER SIT IN



**SPY 260** SINGLE-SEATER SIT IN

**STAND UP PADDLE**



**KOA 10'2** STAND UP PADDLE



**FUN 10'6** INFLATE STAND UP PADDLE



**EXP 12'6** INFLATE STAND UP PADDLE



**PRO 11'** INFLATE STAND UP PADDLE



**MAX 16'** INFLATE STAND UP PADDLE



# Duetto

## MULTI-SEATER SIT ON TOP

The **DUETTO** is a new two-seater kayak that can accommodate 2 adults and a young child. This Sit On Top is equipped with two tilting backrests as standard, offering optimal comfort. Its hull allows both sea and river navigation.

The **DUETTO** is a steering kayak, stable and comfortable.

<b>LENGTH</b>	375 cm
<b>WIDTH</b>	93 cm
<b>DEPTH</b>	28 cm
<b>WEIGHT</b>	32 kg
<b>CAPACITY MAX</b>	240 kg

- 2 PE backrests
- Deckline
- Paddle holder bungees
- 4 PE Carry handles
- Can holders
- 2 storage spaces with strap
- Scupper holes
- Molded footrests

### OPTIONS

- Trolley (P65)
- PFDs (P62)
- Automatic water stopper (P67)
- Dry bags & storage barrels (P66)
- Paddles (P64)

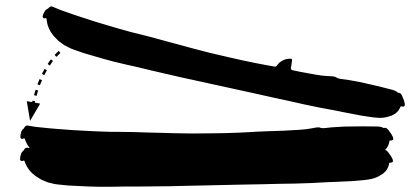

**STACKABLE KAYAKS  
WITH FOLDED BACKS**



**CONTAINS REGENERATED PE**



# Mojito

SINGLE-SEATER SIT ON TOP

The **MOJITO** is the most compact SIT-ON-TOP in the range. It's a fun way to discover kayaking on the sea, lake or river. The **MOJITO** is ideal for discovering the joys of kayak surfing.



<b>LENGTH</b>	250 cm
<b>WIDTH</b>	76 cm
<b>DEPTH</b>	30 cm
<b>WEIGHT</b>	16 kg
<b>CAPACITY MAX</b>	100 kg

- PE Carry handles
- Scupper holes
- D-ring eyelets
- Water bottle holder
- Molded footrests

#### OPTIONS

- Trolley (P65)
- PFDs (P62)
- Automatic water stopper (P67)
- Dry bags (P66)
- Paddles (P64)



CONTAINS REGENERATED PE





# Océan Duo

MULTI-SEATER SIT ON TOP

The **OCEAN DUO** is a SIT-ON-TOP that can accommodate 2 adults + a child.

Self-draining, robust, safe and comfortable, it allows you to discover sea, lake and river hiking and surfing on the small waves of the coast.



<b>LENGTH</b>	370 cm
<b>WIDTH</b>	88 cm
<b>DEPTH</b>	33 cm
<b>WEIGHT</b>	29 kg
<b>CAPACITY MAX</b>	220 kg

## STANDARD VERSION

- Carry handles
- Scupper holes
- D-ring eyelets
- Molded footrests
- Paddle holder bungees
- Storage space with strap
- Deckline

## OPTIONS

- Trolley (P65)
- PFDs (P62)
- Automatic water stopper (P67)
- Dry bags & storage barrels (P66)
- Paddles (P64)

## PACK VERSION = Standard version +

- 2 Luxe seats
- 2 alu paddles 2 parts



CONTAINS REGENERATED PE





# Océan Quattro

MULTI-SEATER SIT ON TOP

The **OCEAN QUATRO** carries 2 adults and 2 children or 3 adults.

Long sea trips are now accessible while enjoying the incomparable comfort and safety benefits of SIT-ON-TOP.



- LENGTH** 412 cm
- WIDTH** 90 cm
- DEPTH** 35 cm
- WEIGHT** 34 kg
- CAPACITY MAX** 260 kg



**PE BACKREST KIT IN OPTION**  
With fixing & strap

- Carry handles
- Scupper holes
- D-ring eyelets
- Molded footrests
- Rear storage space with strap
- Paddle holder bungee
- Deckline

- OPTIONS**
- Trolley (P65)
  - PFDs (P62)
  - Automatic water stopper (P67)
  - Dry bags & storage barrels (P66)
  - Paddles (P64)



**CONTAINS REGENERATED PE**



# Abaco 3.60

SINGLE-SEATER SIT ON TOP

The **ABACO 3.60** is a single-seater sit-on-top ideally suited to all types of sailing, on all types of water, salt or fresh. Its compact design makes it easy to store, transport and maneuver underway. Its width of 76 cm provides considerable stability.

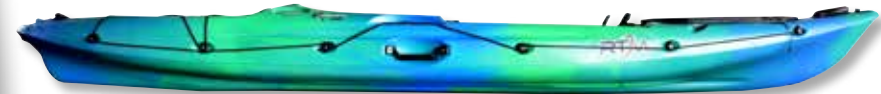

<b>LENGTH</b>	360 cm
<b>WIDTH</b>	76 cm
<b>DEPTH</b>	30 cm
<b>WEIGHT</b>	32.5 kg
<b>CAPACITY MAX</b>	170 kg

- Carry handles
- Scupper holes
- Rear storage area with bungees
- Paddle holders with bungee
- Deckline
- Flush mount rod holders
- Rubber stowage nets
- Central storage with hatch
- Front storage space with hatch

#### OPTIONS

- Trolley (P65)
- PFDs (P62)
- Automatic water stopper (P67)
- Dry bags & storage barrels (P66)
- Paddles (P64)



CONTAINS REGENERATED PE

# Seaview board

UNDERWATER VISION PALM BOARD

Hunting and leisure board in polyethylene.

Secure thanks to multiple handles and supports.  
Ergonomic: the swimmer is comfortably positioned to explore the underwater world through the optical lens.

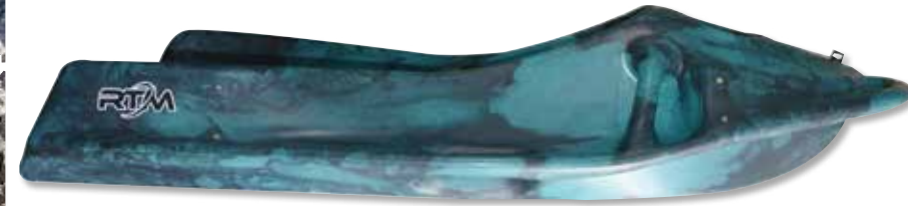

<b>LENGTH</b>	140 cm
<b>WIDTH</b>	65 cm
<b>WEIGHT</b>	8.8 kg

- Integrated handles
- Foam chin guard
- Optical lens

#### OPTIONS

- PFDs (P62)
- Dry bags & storage barrels (P66)



CONTAINS REGENERATED PE



# Disco +

SINGLE-SEATER SIT ON TOP

**DISCO +** displays exceptional paddling levels.

Its slimline design and glide appeal particularly to small size or female paddlers.



<b>LENGTH</b>	428 cm
<b>WIDTH</b>	65 cm
<b>DEPTH</b>	33 cm
<b>WEIGHT</b>	23 kg
<b>CAPACITY MAX</b>	120 kg

- Carry handles
- Scupper holes
- D-ring eyelets
- Molded footrests
- Rear storage space with net
- Deckline

#### OPTIONS

- Trolley (P65)
- PFDs (P62)
- Automatic water stopper (P67)
- Dry bags & storage barrels (P66)
- Paddles (P64)



**CONTAINS REGENERATED PE**



# Mid-Way

SINGLE-SEATER SIT ON TOP

The **MID-WAY** combines the performance of traditional sea kayaks (glide, speed, technical qualities) with the advantages of an SIT-ON-TOP (self-draining, safety, ease of use).

The kayak is fitted with the CARL SYSTEM (Anatomic Length Adjustable Anatomical Scale): between the legs, the paddler is then positioned, fixed as in a kayak sit-in.

The **MID-WAY** allows you to hike for 1 to 3 days.

It has a waterproof front hatch and rear storage space that can accommodate a 24L waterproof barrel.



<b>LENGTH</b>	440 cm
<b>WIDTH</b>	65 cm
<b>DEPTH</b>	34 cm
<b>WEIGHT</b>	23 kg
<b>CAPACITY MAX</b>	140 kg

- Carry handles
- Scupper holes
- D-ring eyelets
- Molded footrests
- Paddle holder bungee
- Rear storage space with net
- Carl-system
- Anti wear keel

#### OPTIONS

- Trolley (P65)
- PFDs (P62)
- Automatic water stopper (P67)
- Dry bags & storage barrels (P66)
- Paddles (P64)



# Tempo

SINGLE-SEATER SIT ON TOP

The **TEMPO** is a superb long hull, comfortable, spacious and fast kayak.

It is really suitable for fitness, hiking, fishing and diving.



<b>LENGTH</b>	450 cm
<b>WIDTH</b>	67 cm
<b>DEPTH</b>	34 cm
<b>WEIGHT</b>	24 kg
<b>CAPACITY MAX</b>	170 kg

- Carry handles
- Scupper holes
- D-ring eyelets
- Molded footrests
- Rear storage space with net
- Front storage space with hatch and strap
- Deckline
- Towing ring

## OPTIONS

- Trolley (P65)
- PFDs (P62)
- Automatic water stopper (P67)
- Dry bags & storage barrels (P66)
- Paddles (P64)



**CONTAINS REGENERATED PE**



# Mezzo STD

SINGLE-SEATER SIT IN

The **MEZZO** is a compact kayak, easy to maneuver. It allows a playful approach to kayaking, on the calm waters & sea shore.

This new kayak combines comfort, stability and glide, regardless the size of the paddler. Its large cockpit makes the boarding and disembarking easier for the sturdiest paddlers.



<b>LENGTH</b>	360 cm
<b>WIDTH</b>	67 cm
<b>DEPTH</b>	34 cm
<b>WEIGHT</b>	22 kg
<b>CAPACITY MAX</b>	135 kg
<b>COCKPIT</b>	92 x 47

- PE seat with foldable backseat
- Carry handles
- Zig-zag footrests
- Rear PE hatch
- Molded in basin
- 1/2 front bulkhead
- Back bulkhead
- Integrated thigh support
- Deckline
- Front & rear deck bungees

## OPTIONS

- Trolley (P65)
- PFDs (P62)
- Dry bags & storage barrels (P66)
- Paddles (P64)

# Taiki EVO

SINGLE-SEATER SIT ON TOP

The **TAIKI** is the most popular solo kayak for professionals because of its strength, rigidity and ability to paddle even being loaded.

Its tilting backrest in polyethylene offers an ideal comfort to the users.



<b>LENGTH</b>	345 cm
<b>WIDTH</b>	80 cm
<b>DEPTH</b>	32 cm
<b>WEIGHT</b>	23 kg
<b>CAPACITY MAX</b>	150 kg

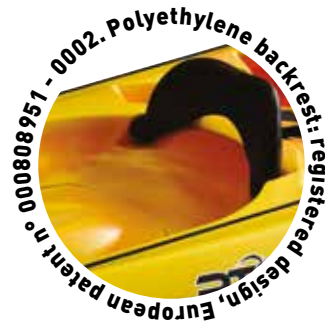

- Rubber handle tubes front and back
- Lateral integrated handles
- Barrel strap (max 50L)
- PU keel
- Molded footrests
- Scupper holes
- PE backrest

#### OPTIONS

- PFDs (P62)
- Automatic water stopper (P67)
- Dry bags & storage barrels (P66)
- Paddles (P64)

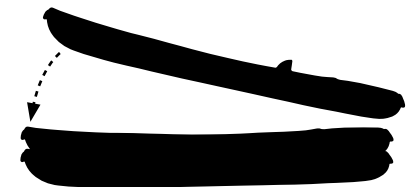

**STACKABLE KAYAKS  
WITH FOLDED BACKS**







# Tango EVO

SINGLE-SEATER SIT ON TOP

The **TANGO EVO** has a foldable PE backrest. Strong & comfy, this new option is a really plus for your touring sessions.

Equipped with a flat-bottom hull, the **TANGO EVO** is designed for river, lake and quiet seaside paddling.



<b>LENGTH</b>	351 cm
<b>WIDTH</b>	78 cm
<b>DEPTH</b>	34 cm
<b>WEIGHT</b>	26 kg
<b>CAPACITY MAX</b>	140 kg



- Rubber handle tubes front and back
- Lateral integrated handles
- Barrel strap (max 50L)
- D-ring eyelets
- Molded footrests
- Scupper holes
- PE backrest



**STACKABLE KAYAKS  
WITH FOLDED BACKS**

## OPTIONS

- PFDs (P62)
- Automatic water stopper (P67)
- Dry bags & storage barrels (P66)
- Paddles (P64)



# Optimo EVO

MULTI-SEATER SIT ON TOP reinforced

The **OPTIMO EVO** is a 2/3 seats kayak offering an alternative to traditional canoes.

The strengths are its stability, loading capacity, maneuverability and sturdiness.



<b>LENGTH</b>	432 cm
<b>WIDTH</b>	93 cm
<b>DEPTH</b>	34 cm
<b>WEIGHT</b>	48 kg
<b>CAPACITY MAX</b>	220 kg



- Threaded drain plug with base
- Rubber handle tubes front and back
- Lateral integrated handles
- Molded footrests
- Scupper holes
- 2 barrel straps (max 50L)
- 2 PE backrests
- Bow cap

#### OPTIONS

- Automatic water stopper (P67)
- Dry bags & storage barrels (P66)
- Paddles (P64)



**STACKABLE KAYAKS  
WITH FOLDED BACKS**

# Tribal Pro

MULTI-SEATER SIT ON TOP

Sit On Top kayak made for 3 adults on board. This model, low on the water, is the favorite of the rental shops for medium touring trips, on shallow water.



<b>LENGTH</b>	405 cm
<b>WIDTH</b>	90 cm
<b>DEPTH</b>	32 cm
<b>WEIGHT</b>	37 kg
<b>CAPACITY MAX</b>	250 kg

- Handles front and back
- Lateral handles
- 2 barrel straps (max 24L)
- Molded footrests
- Scupper holes

## OPTIONS

- Dry bags & storage barrels (P66)
- Paddles (P64)





# Tarka

**MULTI-SEATER SIT ON TOP**

The **TARKA** is the culmination of the specifications requested by professionals: higher self-draining wells inserted into the hull tunnels; stiffened kayak deck; integrated tip reinforcement; rigid side handles; optimized storage spaces for increased paddler comfort.

Accommodates 2 to 3 people.



<b>LENGTH</b>	445 cm
<b>WIDTH</b>	85 cm
<b>DEPTH</b>	43 cm
<b>WEIGHT</b>	47 kg
<b>CAPACITY MAX</b>	270 kg

- Front and rear rental handles
- Rigid side handles
- Bottle-holder straps (max 50L)
- Front tip reinforcement
- Molded footrests
- Scupper holes

#### **OPTIONS**

- Automatic water stopper (P67)
- Dry bags & storage barrels (P66)
- Paddles (P64)



**STACKABLE KAYAKS**



# Tanargue 2

MULTI-SEATER SIT ON TOP

The **TANARGUE 2** is a 2/3-seater kayak, with no self-draining wells or hard points in the hull, making it ideal for rough rivers.

The **TANARGUE 2** combines comfort for long trips, easy and safe navigation for beginners and, of course, plenty of carrying capacity.



<b>LENGTH</b>	445 cm
<b>WIDTH</b>	85 cm
<b>DEPTH</b>	43 cm
<b>WEIGHT</b>	47 kg
<b>CAPACITY MAX</b>	270 kg

- Front and rear handles
- Side handles
- Bottle-holder straps (max 50L)
- Front tip reinforcement
- Molded footrests

## OPTIONS

- Automatic water stopper (P67)
- Dry bags & storage barrels (P66)
- Paddles (P64)



**STACKABLE KAYAKS**



# Brio

## MULTI-SEATER TOURING

Lightweight, the **BRIO** is a very comfy touring kayak thanks to its ergonomic seats.

It is easy to carry thanks to its folding backrests. Ideal for paddling sessions with 2 adults or with a child on the central seat. It can also be used alone.



<b>LENGTH</b>	395 cm
<b>WIDTH</b>	83 cm
<b>DEPTH</b>	40 cm
<b>WEIGHT</b>	33 kg
<b>CAPACITY MAX</b>	230 kg

- PE seats with foldable backrests + 1 central child seat
- Rubber handles front and rear
- Rear barrel strap (max 24L)
- Front deck net
- Threaded drain plug

### OPTIONS

- Trolley (P63)
- PFDs (P62)
- Dry bags & storage barrels (P66)
- Paddles (P64)



# Canada

**MULTI-SEATER CANOE**

Inspired by the old wooden canoes, the **CANADIA** promotes safe and comfortable paddling.

Two children can sit on the central bench safely since it is the only unsinkable canoe in its category. It can carry 4 people and gear. Ideal for family days out.



<b>LENGTH</b>	470 cm
<b>WIDTH</b>	93 cm
<b>DEPTH</b>	45 cm
<b>WEIGHT</b>	47 kg
<b>CAPACITY MAX</b>	320 kg

- Handles front and back
- 2 straps for barrels

If 2 barrels are fitted, the canoe can accept only 2 seaters.

#### **OPTIONS**

- PFDs (P62)
- Dry bags & storage barrels (P66)
- Paddles (P64)



# Riviera

MULTI-SEATER CANOE

Open canoe, the **RIVIERA** is the ideal boat to discover the rivers with the family.

This sturdy and stable boat can be used sitting or kneeling. A must for beginners, it is also recommended for professional use.

The **RIVIERA** is available in a Standard and Comfort version, offering two standard PE backrests on the front and rear seats.



<b>LENGTH</b>	464 cm
<b>WIDTH</b>	90 cm
<b>DEPTH</b>	37 cm
<b>WEIGHT</b>	43 kg
<b>CAPACITY MAX</b>	295 kg

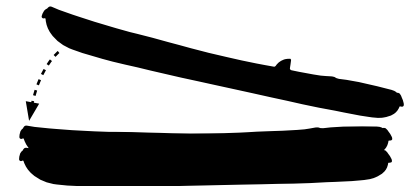

**STACKABLE KAYAKS  
WITH FOLDED BACKS**

- Handles front and rear
- Back seat
- Front seat
- Central bench
- Front and back PE backrests

## OPTIONS

- PFDs (P62)
- Dry bags & storage barrels (P66)
- Paddles (P64)





# Riviera XL

MULTI-SEATER CANOE

**RIVIERA XL**, the monospace of canoes : thanks to its additional central bench, it can accommodate 4 adults or two adults and 4 children.

Stable, maneuverable and comfortable, the **RIVIERA XL** welcomes all types of paddlers for a few hours or a day trip.

The **RIVIERA XL** comes with two Pe backrests on the front and rear seats.



<b>LENGTH</b>	500 cm
<b>WIDTH</b>	100 cm
<b>DEPTH</b>	37 cm
<b>WEIGHT</b>	48 kg
<b>CAPACITY MAX</b>	350 kg

- Handles front and rear
- Back seat
- Front seat
- 2 central benches
- Front and back PE backrests

#### OPTIONS

- PFDs (P62)
- Dry bags & storage barrels (P66)
- Paddles (P64)

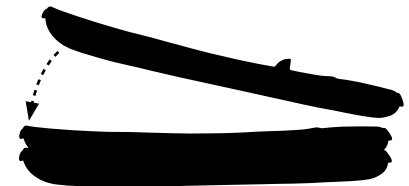

**STACKABLE KAYAKS  
WITH FOLDED BACKS**

 HIRO





# Hiro Impulse Drive

ANGLER KAYAK

The **HIRO Impulse drive** is a kayak with a slim, stable, fast and ergonomic design, allowing hands-free fishing.

Powered by the **Impulse Drive**, this proven system is lightweight. It moves forward and backward. Steering is provided by a wide rudder controlled by a joystick on the port side of the kayak.

Its comfortable premium seat adjusts to the fisherman's size. The space in front of the seat features a large platform for fishing while standing.

<b>LENGTH</b>	362 cm
<b>WIDTH</b>	87 cm
<b>DEPTH</b>	40 cm
<b>WEIGHT</b>	42 kg
<b>CAPACITY MAX</b>	180 kg

## OPTIONS

- Trolley HIRO (P68)
- PFDs (P68)
- Automatic water stopper (P67)
- Dry bags & storage barrels (P66)



- Drain plug
- 2 carry handles
- 4 scupper holes
- Rear storage with bungee
- 3 paddle holders with bungee (1 front + 2 lateral)
- Deckline
- 4 flush mount rod holders
- Adjustable rod holder
- 4 aluminum side rails
- Front storage space with hatch
- Rudder steerable with a joystick

- 2 automatic stoppers M
- IMPULSE DRIVE pedals
- Asymmetrical double alu paddle
- HIRO premium chair



# Mezzo LUXE

SINGLE SEATER SIT-IN

The **MEZZO LUXE** is a compact, comfortable and steerable touring kayak. Its rear storage compartment allows you to carry everything you need for a trip lasting from a few hours to 2 days.

Its large coaming and adjustable, ergonomic Hi-Class seat make this kayak comfortable and accessible to all sizes.



<b>LENGTH</b>	360 cm
<b>WIDTH</b>	67 cm
<b>DEPTH</b>	37 cm
<b>WEIGHT</b>	25 kg
<b>CAPACITY MAX</b>	130 kg
<b>COCKPIT</b>	92 x 47

- 2 carry handles
- Deckline
- 1 towing ring
- 1 front deck bungee
- 1 Hi-Class seat with adjustable backrest
- Mixed footrests
- 1/2 bulkhead
- Rear storage area with hatch
- Paddle holders with bungee
- 1 skeg

#### OPTIONS

- Trolley (P65)
- PFDs (P62)
- Dry bags & storage barrels (P66)
- Paddles (P64)



# Tiwok EVO

SINGLE SEATER SIT-IN

Stable, elegant & speedy, **TIWOK EVO** toward better comfort thanks to the new Hi Class seat & backrest and large cockpit.

All size paddlers can enjoy day trips or excursions on sea, lakes & rivers thanks to this polyvalent kayak.

Possibility to install an **OPTIONAL RUDDER**.

<b>LENGTH</b>	440 cm
<b>WIDTH</b>	60 cm
<b>DEPTH</b>	34 cm
<b>WEIGHT</b>	23 kg
<b>CAPACITY MAX</b>	130 kg
<b>COCKPIT</b>	90 x 45

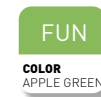

## VERSION LUXE

- Cale-pieds réglables mixtes
- Ligne de vie
- Compartiments de rangement avec trappe
- Filet de pont avant
- Siège HI-CLASS avec dossier réglable
- Quille anti-usure
- Logements pour bidons sur pont arrière avec sangles

## VERSION FUN

- Cale-pieds réglables mixtes
- Ligne de vie
- Compartiments de rangement avec trappe
- Filet de pont avant
- Dossier thermo-comfort
- Quille anti-usure

## OPTIONS

- Trolley (P65)
- PFDs (P62)
- Dry bags & storage barrels (P66)
- Paddles (P64)



# Miwok

SINGLE SEATER SIT-IN

**MIWOK** is one of the most stylish and elegant sea kayaks. Its speed, stability, and comfort enable you to paddle further for longer.



<b>LENGTH</b>	500 cm
<b>WIDTH</b>	60 cm
<b>DEPTH</b>	35 cm
<b>WEIGHT</b>	25 kg
<b>CAPACITY MAX</b>	140 kg
<b>COCKPIT</b>	79 x 45

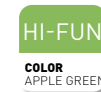

## HI-LUXE VERSION

- Mixed footrests
- Deckline
- Storage compartments with hatch
- Front deck net
- HI-CLASS seat with adjustable backrest
- PU keel + screws
- Front deck net
- Deck areas for barrels with strap
- Rudder

## HI-FUN VERSION

- Mixed footrests
- Deckline
- Storage compartments with hatch
- Front deck net
- Towing ring
- PE backrest
- Front and rear deck bungee
- Rudder

## OPTIONS

- Trolley (P65)
- PFDs (P62)
- Dry bags & storage barrels (P66)
- Paddles (P64)





# Ysak

SINGLE SEATER SIT-IN

Comfortable and high-performance, the **YSAK** is a perfect mile-spinner.

The ergonomic design and fine water inlets in the bow are a pleasure to navigate, and ensure that the kayak holds up well even in rough seas.



<b>LENGTH</b>	506 cm
<b>WIDTH</b>	57 cm
<b>DEPTH</b>	30 cm
<b>WEIGHT</b>	26 kg
<b>CAPACITY MAX</b>	120 kg
<b>COCKPIT</b>	84 x 46

#### **LUXE VERSION with skeg**

- Front storage compartment with round hatch
- Back storage compartment with access to both hatches
- Thermo-comfort backrest
- PE seat
- Deckline
- Carry handles
- Front & rear bungees
- Retractable skeg
- Mixed footrests

#### **HI-LUXE VERSION with skeg**

- 2 Back storage compartments with access to both hatches
- PE seat with pad
- Rudder

#### **OPTIONS**

- Trolley (P65)
- PFDs (P62)
- Dry bags & storage barrels (P66)
- Paddles (P64)



# Biwok EVO

MULTI SEATER SIT-IN  
HI-LUXE

Kayakers can adjust the depth of the **BIWOK**'s removable centreboard to suit the strength of the wind and current, and more easily correct their course.

The hull remains unchanged, retaining its excellent gliding ability and stability.



<b>LENGTH</b>	530 cm
<b>WIDTH</b>	67cm
<b>DEPTH</b>	35 cm
<b>WEIGHT</b>	34 kg
<b>CAPACITY MAX</b>	240 kg
<b>COCKPIT</b>	92 x 47

- Deckline
- Front deck bungee
- Central deck bungee
- Rear black bungee
- Storage compartments with oval hatch
- HI-CLASS seats
- Carry handles
- Paddle holder bungees
- PU keel
- Pairs of mixed footrests
- Rudder
- Retractable skeg

#### OPTIONS

- Trolley (P65)
- PFDs (P62)
- Dry bags & storage barrels (P66)
- Paddles (P64)





# Nelo 510

## SURFSKI

A single-seater surfski made from two-layer polyethylene, ensuring good rigidity and one of the lowest weights on the market.

The **NELO 510** is the ideal entry-level surfski for beginners, easy to handle, durable and stable. It's easy to handle, durable and stable, suitable for children and adults alike, and ideal for discovering downwind paddling. It combines the beautiful lines of a composite surfski with an extra-stable, durable boat.



<b>LENGTH</b>	510 cm
<b>WIDTH</b>	55 cm
<b>DEPTH</b>	29 cm
<b>WEIGHT</b>	22 kg
<b>CAPACITY MAX</b>	110 kg



- Fully adjustable leg support, depth, inclination, height, polyamide and stainless steel construction.
- Rigid foot strap 2 positions, can be handled with the foot.
- Oval fabric hatch
- Rear storage compartment
- Front and rear handle
- Integrated side handles
- Rear axle elastic
- Specific «surf ski» rudder
- Internal foam partitions

### OPTIONS

- Trolley (P65)
- PFDs (P62)
- Dry bags & storage barrels (P66)
- Paddles (P64)



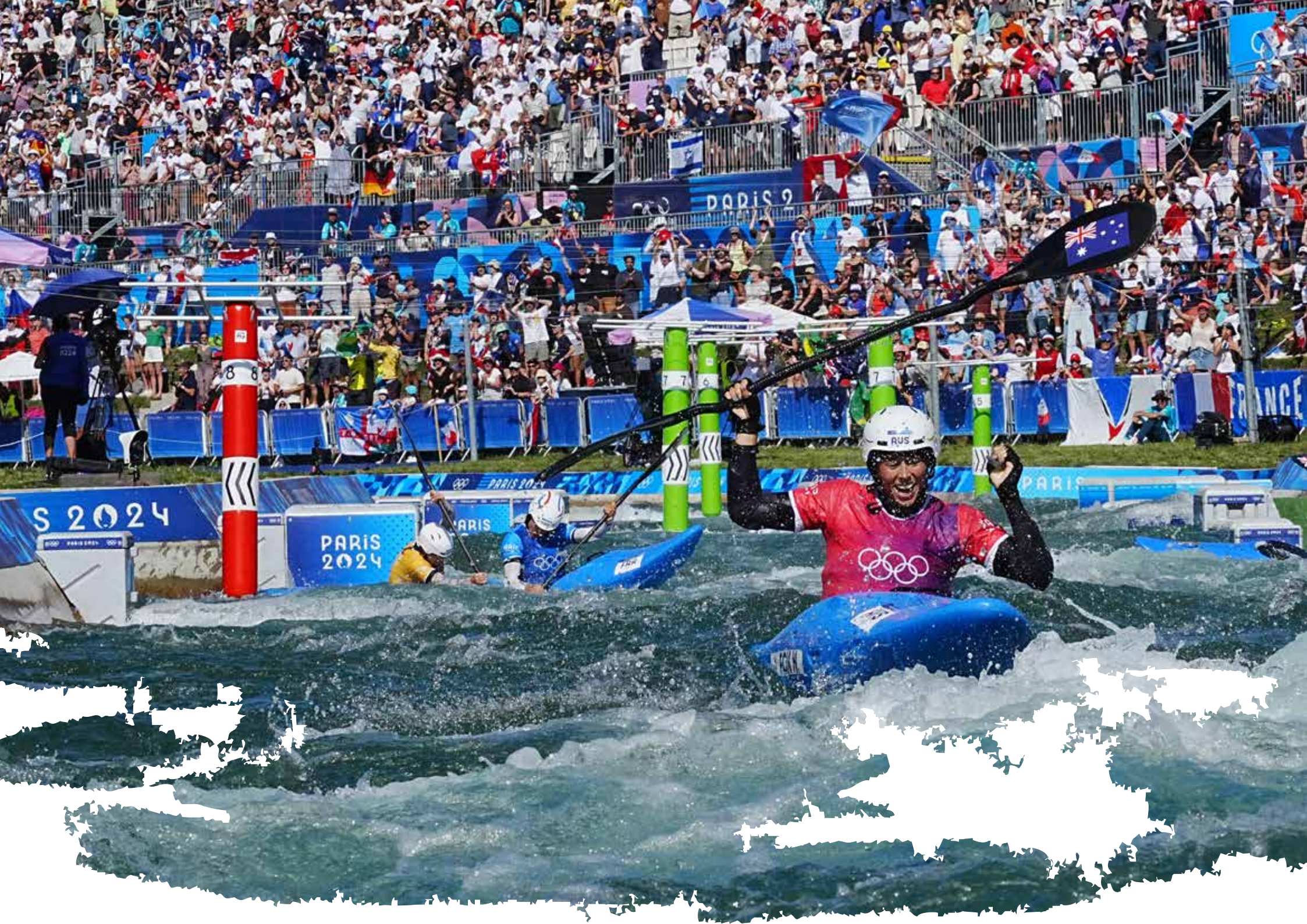

# Paname / Paname S

KAYAK CROSS / PLAYBOATING

**New for 2023 :** a whitewater kayak designed by **Zig Zag** in collaboration with members of the French Slalom team. The **PANAME** is designed for paddlers looking for thrills in competition as well as on the river. A boat designed by the elite but accessible to the greatest number. Speed, fluidity and reactivity are the watchwords of this new model, developed for fun paddling and podium finishes in kayak cross-country.

Its technical features make for easy, high-performance navigation:

Optimized front volume distribution for easy drop-offs, overcoming rollers, landing on jumps or ramps.

Tail cut for fast, stable rotations.

Tight rear end for greater speed and glide.

Low deck height and recessed coaming facilitate kayaker movement and passage through kayak cross doors.

Available in 2 sizes, the **PANAME** and **PANAME S** adapt to the morphologies of male and female athletes looking for a kayak that matches their volume and width, allowing them to express their full potential.

	<b>PANAME</b>	<b>PANAME S</b>
<b>LENGTH</b>	274 cm	274 cm
<b>WIDTH</b>	63.5 cm	60 cm
<b>COCKPIT</b>	88 x 48 cm	88 x 48 cm
<b>WEIGHT</b>	18 kg	18 kg
<b>CAPACITY MAX</b>	70/85 kg	55/70 kg

- Adjustable plate footrests
- Pawl adjustable backrest
- Adjustable thigh braces
- PE seat
- PE rail
- Front and Rear Foam block

#### OPTIONS

- Trolley (P65)
- PFDs (P62)
- Paddles (P64)



**CONSTRUCTION : SUPER-LINEAR  
HIGH-DENSITY POLYETHYLENE**



**CONTAINS REGENERATED PE**





# SQUALY

## RIVER INITIATION

The **SQUALY** is a school kayak, allowing the practice of kayak activity from a young age. Adapted to young paddlers, it facilitates the acquisition of kayak technique for fun and safe navigation in calm water and also in rivers during slalom descents of torrents or artificial ponds. (Max Class 2 / passage 3).

The removable keel/drift is an ideal tool, allowing young paddlers to concentrate on propulsion and not on maintaining the direction of the **SQUALY**.

<b>LENGTH</b>	223 cm
<b>WIDTH</b>	57 cm
<b>DEPTH</b>	30.5 cm
<b>WEIGHT</b>	13 kg
<b>CAPACITY MAX</b>	60 kg
<b>COCKPIT</b>	71 x 43 cm



- 2 front and rear carrying handles
- 2 rear deck safety handles
- Nave plug
- Integrated knee braces
- Seat
- Thermo-comfort backrest
- Front and rear foam stanchions
- Adjustable footrest
- Integrated paddle holder
- 2 water extractors

### OPTIONS

- Trolley (P65)
- PFDs (P62)
- Paddles (P64)





# Mad'gic

RIVER INITIATION

The **MAD'GIC** is an entry level polo kayak ideal for clubs, centers, and rental operators. The boat suits both lighter and heavier paddlers.

A stable platform for shooting and tackling. The **MAD'GIC** is also ideal as a pool trainer and for moderate river running.



<b>LENGTH</b>	296 cm
<b>WIDTH</b>	60 cm
<b>DEPTH</b>	31 cm
<b>WEIGHT</b>	16 kg
<b>CAPACITY MAX</b>	95 kg
<b>COCKPIT</b>	84.5 x 50



- Integrated seat
- Notches footrests
- Front and rear handles

#### OPTIONS

- Trolley (P65)
- PFDs (P62)
- Paddles (P64)



# Strim Junior Senior

RIVER INITIATION

Multi-purpose kayak for teenagers and adults who wish to learn and discover kayaking in calm and white water.

Paddling clubs and schools appreciate this kayak with its **CLUB FEATURES**, the bare essentials to get started and discover the kayak.



	JUNIOR	SENIOR
<b>LENGTH</b>	310 cm	315 cm
<b>WIDTH</b>	57 cm	60 cm
<b>DEPTH</b>	30 cm	32 cm
<b>WEIGHT</b>	13 kg	18 kg
<b>CAPACITY MAX</b>	80 kg	115 kg
<b>COCKPIT</b>	79 x 45	85.5 x 48.5



## CLUB VERSION

- Bow cap
- Notches footrests
- Carry handles
- Rear foam bulkhead
- Rear buoyancy foam
- Black PE seat

## SUPER VERSION = Club version +

- Kneebrace
- Thermo-comfort backrest

## OPTIONS

- Trolley (P65)
- PFDs (P62)
- Paddles (P64)



# SX 230 285 RIVER INITIATION

The **SX 230** is the ideal kayak for young beginners. Light, compact, easy to handle, children quickly adopt this safe kayak.

The **SX 285** is a SIT-ON-TOP kayak for teenagers and adults designed to get started and progress in whitewater.

The 2 kayaks are fitted with the CARL SYSTEM (Anatomic Length Adjustable Anatomical Scale): between the legs, the paddler is then positioned, fixed as in a kayak sit-in.



	<b>SX230</b>	<b>SX285</b>
<b>LENGTH</b>	230 cm	285 cm
<b>WIDTH</b>	67 cm	71 cm
<b>DEPTH</b>	24 cm	30 cm
<b>WEIGHT</b>	12 kg	22 kg
<b>CAPACITY MAX</b>	70 kg	130 kg



COLOR  
RED YELLOW



COLOR  
GREEN YELLOW

- Storage space with strap
- Carry handles
- Rear tie-down handles
- Integrated side handles
- Anti-wear PU keels + screws
- Scupper holes
- CARL SYSTEM

### OPTIONS

- Trolley (P65)
- PFDs (P62)
- Paddles (P64)





# SPY<sup>235</sup> <sup>260</sup>

## RIVER INITIATION

This versatile river runner was designed to satisfy the dynamic paddler.

It is an all-terrain river kayak, suitable for paddlers of all levels and all types of rivers.



	SPY235	SPY260
<b>LENGTH</b>	235 cm	260 cm
<b>WIDTH</b>	65 cm	64 cm
<b>DEPTH</b>	36 cm	36 cm
<b>WEIGHT</b>	19 kg	20 kg
<b>CAPACITY MAX</b>	110 kg	120 kg
<b>COCKPIT</b>	84 x 46	92 x 52



### CLUB VERSION

- PE seat
- Thermo-comfort backrest
- Notches footrests
- Front and rear bulkheads
- Threaded drain plug
- Security grab handles
- Carry handles

### SUPER VERSION = Club version +

- PE seat with seat pad
- River Platform footrests
- Adjustable & reinforced thermo-comfort backrest

### OPTIONS

- PFDs (P62)
- Paddles (P64)





# SUP PE KOA

PE STAND UP PADDLE

**KOA** is the new polyethylene SUP created by **RTM**. This new concept replaces the SUP PE 10'.

The advantages of this product are its rigidity, avoiding any deformation of the product, its greater volume to increase bearing capacity and its non-slip geometric pad.

Ideal for leisure centres, rental bases and clubs.

Its 3 handles allow to secure the boards together during storage periods.



<b>LENGTH</b>	310 cm / 10'2
<b>WIDTH</b>	90 cm / 35"
<b>DEPTH</b>	24 kg / 53 lbs
<b>VOLUME</b>	230 L
<b>CAPACITY MAX</b>	140 kg



- Elastomer fin
- Integrated handles
- Threaded drain plug
- Front deck bungee

## OPTIONS

- SUP Paddles (P69)
- PFDs (P62)
- Dry bags & storage barrels (P66)

# SUP 10'6 FUN

INFLATE STAND UP PADDLE

Rigid and lightweight board thanks to its Fusion Technology construction.

This SUP is the ideal partner for your sea trips, lakes and rivers or your first surfing sessions.

This versatile board is accessible to all paddlers!

**Manufacturing : Fusion technology.**



<b>LENGTH</b>	320 cm / 10'6
<b>WIDTH</b>	76.4 cm / 30"
<b>DEPTH</b>	15 cm / 6"
<b>VOLUME</b>	304 L
<b>CAPACITY MAX</b>	100 kg
<b>TECHNOLOGY</b>	Fusion Technology

- Paddle (3 parts)
- Leash
- Pump
- Simple transport bag
- Repair kit
- Removable fin

#### OPTIONS

- PFDs (P62)
- Dry bags & storage barrels (P66)

# SUP 12'6 EXP

INFLATE STAND UP PADDLE

To satisfy the regulars and insiders, the **SUP EXP 12'6** is an alternative to the 10'6, offering the opportunity to discover 1-day touring or gliding.

Bag and pump provided.

**Manufacturing : Fusion technology.**



<b>LENGTH</b>	381 cm / 12'6
<b>WIDTH</b>	76.4 cm / 30"
<b>DEPTH</b>	15 cm / 6"
<b>VOLUME</b>	350 L
<b>CAPACITY MAX</b>	120 kg
<b>TECHNOLOGY</b>	Fusion Technology

- Double action HP pump
- Luxe transport bag
- Repair kit
- Removable fin

#### OPTIONS

- SUP paddles (P69)
- PFDs (P62)
- Dry bags & storage barrels (P66)



# SUP 11' PRO

INFLATE STAND UP PADDLE

The versatility of the 11' Pro inflatable SUP board makes it suitable for all your customers' needs. The SUP PRO 11' offers increased stability, especially for taller people. It also allows two people to discover SUP with an adult or a child sitting on the front, or even his faithful companion.

**Manufacturing : dropstitch - double skin PVC 1000 D - Side reinforcements.**



<b>LENGTH</b>	335.3 cm / 11'
<b>WIDTH</b>	86.4 cm / 34"
<b>DEPTH</b>	15 cm / 6"
<b>VOLUME</b>	356 L
<b>CAPACITY MAX</b>	120 kg
<b>TECHNOLOGY</b>	Drop Stitch

- Repair kit
- Removable fin

## OPTIONS

- SUP paddles (P69)
- PFDs (P62)
- Dry bags & storage barrels (P66)

# SUP 16' MAX

INFLATE STAND UP PADDLE

Want to evolve and explore new horizons?

SUP MAX, for SUP with family or friends, up to 5 adults.

**Manufacturing : dropstitch - double skin PVC 1000 D - Side reinforcements.**



<b>LENGTH</b>	488 cm / 16'
<b>WIDTH</b>	153 cm / 60"
<b>DEPTH</b>	20 cm / 8"
<b>VOLUME</b>	1280 L
<b>CAPACITY MAX</b>	450 kg
<b>TECHNOLOGY</b>	Drop Stitch

- Repair kit
- Removable fin

## OPTIONS

- SUP paddles (P69)
- PFDs (P62)
- Dry bags & storage barrels (P66)

# Accessories SUP



## COIL KNEE LEASH FOR SUP

The Leash 10'you will be needed to ensure your safety and the safety of others in the water.



## STAND UP PADDLE PADDLES

### 1 - STANDARD PADDLE

**Shaft :** Alu 30mm

**Length :**

Black T-grip -- 175 cm

Blue T-grip -- 185 cm

Yellow T-grip -- 195 cm

Red T-grip -- 205 cm

**Weight :** 900 g

With alu shaft, polypro blade - 1 part

### 3 - VARIO SPORT PADDLE

**Shaft :** Alu 30mm

**Length :** 170-210cm

**Weight :** 900 g

With alu shaft, white and blue nylon blade - 2 parts



1

2



## HIGH PRESSURE HAND PUMP

Universal pump for inflating any type of inflatable sup.

- Single action hand pump
- Aluminum body
- Delivered with double effect manometer

## UNIVERSAL ADAPTATOR FOR COMPRESSOR

This valve adapter will allow you to inflate your SUPS directly with your compressor.

**Don't forget to install a pressure gauge to avoid exceeding the recommended pressure.**





## KORO PFD 50N

Simple, functional and ergonomic, suitable for all paddle sports. Zipper closure, side and shoulder buckle adjustments, zippered pocket

420D polyester  
50N ISO norm 12402-5

**XS/S** (45N)  
**M/L** (50N)  
**XL/XXL** (55N)



## FOX E PFD 50N

PVC foam vest, soft and ergonomic. Its comfort and lightness are appreciated during hikes and walks.

Nylon 420D ripstop  
50N ISO norm 12402-5

**XS/S** (45N)  
**M/L** (50N)  
**XL/XXL** (55N)



## JADE PFD 50N

A simple and discreet vest ideal for sup, surfski and kayak in general. This vest has an inguinal strap for all sizes.

420D polyester  
50N ISO norm 12402-5  
and 12402-6 (XXS)

**XXS** (40N)  
**XS/S** (45N)  
**M/L** (50N)  
**XL/XXL** (55N)



## BASS PFD 50N

Complete and performing, a PFD adapted for fishing.

420D polyester  
50N ISO norm 12402-5

**M/L** (65N) | **XL/XXL** (70N)



## RAPID 70N

A safe and simple vest with great comfort.

Nylon 420D ripstop

70N ISO norm 12402-5

**XS** (40N - PURPLE FLOWER)  
**S/M** (55N - YELLOW FLOWER)  
**M/L** (70N - RED FLOWER)  
**XL** (70N - GREEN FLOWER)  
**XXL** (70N - BLACK FLOWER)



## MAYA PFD 100N

A vest adapted for children.

Nylon 420D ripstop

100N ISO norm 12402-4

**T1** (100N) | **T2** (100N)



After each session, we recommend rinsing your equipment with clean water.

You should also regularly check the integrity of your vest (seams, buckles, foam).

## SIZE

<b>T1</b>	15/30 kg
<b>T2</b>	30/40 kg
<b>XXS</b>	30/40 kg
<b>XS/S</b>	40/60 kg
<b>M/L</b>	60/80 kg
<b>XL/XXL</b>	+80 kg

# Canoe / Kayak Paddles



## 1 - TENDANCE PADDLE ALU SHAFT 1 PART

Paddle 1 part, Double paddle with asymmetrical white polypro blades, alu shaft with drip rings.

**Shaft :** Alu 30mm / 1.2"

**Length :** 210-220cm / 83" - 87"

**Weigh :** 1 kg / 2.2 Lbs

## 2 - TENDANCE PADDLE ALU SHAFT 2 PARTS

Paddle 2 parts, Double paddle with asymmetrical white polypro blades, alu shaft with drip rings.

**Shaft :** Alu 30mm / 1.2"

**Length :** 220cm / 87"

**Weigh :** 1 kg / 2.2 Lbs

## 3 - TENDANCE PADDLE 2-PART FIBER/CARBON HANDLE

Two-piece paddle with telescopic glass/carbon shaft, vario E-Lock. Adjustable over 15 cm (210/225 cm). Eyedropper Asymmetrical white polypro blades.

**Handle :** 70% Fiber / 30% Carbon 15 cm

**Length :** 210 to 225cm

**Weigh :** 1 kg

## 4 - PAGAIE ELEGANCE MANCHE ALU 2 PARTIES

Paddle 2 parts, Double paddle with asymmetrical white polypro blades, alu shaft with drip rings.

**Shaft :** Alu 30mm / 1.2"

**Length :** 215cm / 85"

**Weigh :** 1 kg / 2.2 Lbs

## 4 - JUNIOR / SENIOR PADDLE JUNIOR

With alu shaft, symmetrical riveted polypro blades. 1 part

**Shaft :** Alu 28mm / 1.1"

**Length :** 170-190cm / 67" - 75"

**Weigh :** 1 kg / 2.2 Lbs

## SENIOR

**Shaft :** Alu 30mm / 1.2"

**Length :** 200-220cm / 79" - 87"

**Weigh :** 1.2 kg / 2.2 lbs

## 5 - CANOE PADDLE

1 part paddle, polypro blades.

**Shaft :** Alu 30mm / 1.2"

**Length :**

Yellow T-grip -- 135 cm

Red T-grip -- 140 cm

Black T-grip -- 145 cm

Blue T-grip -- 150 cm

Yellow T-grip -- 160 cm

**Weigh :** 900 g / 1.98 Lbs

## POLYVALENT TRANSPORT TROLLEY

### «ROLL'IN»

Delivered with 1 strap.



## SOT TRANSPORT TROLLEY «KIROOL»

Aluminum structure.

All Sit on Top models except MID-WAY.



## STAINLESS STEEL SOT TRANSPORT TROLLEY

Aluminum structure. All Sit on Top models.

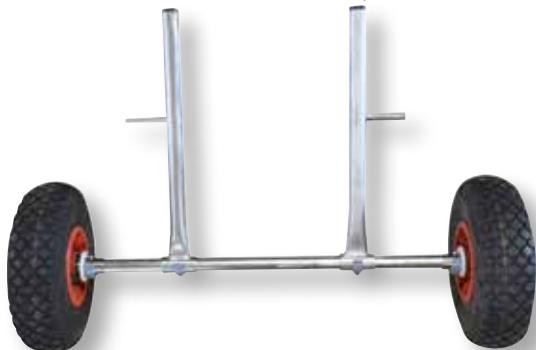

## KAYAK TRANSPORT TROLLEY SMALL MODEL

In anodized aluminum

Equipped with strap and kickstand



## KAYAK TRANSPORT TROLLEY SIT ON TOP

In anodized aluminum

Candles with rubber protection

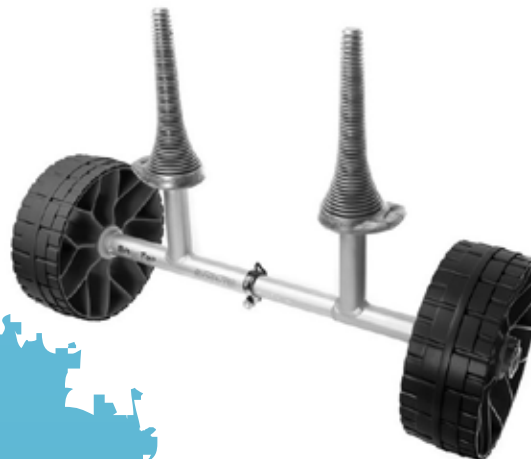

## DELUXE SEAT

Complete seat in foam and coated fabric



## COMFORT + BACKREST

With fixing



## HI-COMFORT SEAT

With fixing







# Dry bags & storage barrels

## DRY BAGS

Made of 500D PVC - Strong and functional.

5L 

20L    Supplied with strap for shoulder transport

40L  Supplied with 2 straps for backpack transport



## STORAGE BARRELS

PEHD food quality, closing with a waterproof covering.

Blanc avec couvercle rouge (6L) ou jaune (15L, 24L et 50L)

**6L** opening = 16 cm / 6";  $\emptyset$  = 24 cm / 9"; Height = 19.5 cm / 7"; Weight = 800 gr / 1.7 Lbs

**15L** opening = 20 cm / 8";  $\emptyset$  = 30,5 cm / 12"; Height = 33 cm / 13"; Weight = 1140 gr / 2.5 Lbs

**24L** opening = 20 cm / 8";  $\emptyset$  = 30,5 cm / 12"; Height = 44 cm / 17"; Weight = 1320 gr / 2.9 Lbs

**50L** 2-part screw-on cover. 2 carrying handles - Opening = 30 cm / 12";  
 $\emptyset$  = 41 cm / 16"; Height = 50 cm / 20"; Weight = 2800 gr / 6.2 Lbs



## MOORING STRAPS

The pair. L = 3m80 / 118"



## KNEE BRACE KIT

Ergonomic & adjustable



## PADDLE LEASH

L=1m60 / 39"



## AUTOMATIC WATER STOPPERS

Kit of 2

M : For all RTM models

L : For all DAG models



# Accessories kayak



# Buoyancy reserve



## BUOYANCY RESERVE

Strong PU / Nylon - Screw-in valve

- ❶ 8 Litres RED Front Slalom Lateral A
- ❷ 16 LITRES RED NARROW LATERAL B
- ❸ 20 LITRES RED LATERAL B
- ❹ 40 LITRES RED STERN TIP
- ❺ 60 LITRES RED STERN TIP
- ❻ 35 LITRES RED CANOE BOW TIP

# Angler Accessories



**IMPULSE DRIVE PEDAL  
PROPELLER LARGE  
MODEL**  
GM 30 CM



**PREMIUM FISHING  
SEAT**  
ABACO 3.60, 4.20 & RYTMO



**HIRO TROLLEY**  
Stainless steel with mounting brackets  
to be screwed on the deck of the Hiro.

## FLUSH MOUNTED ROD HOLDER

D = 42mm / 1.6" + plug joint  
Option: Kit 2 fixed rod holders with factory assembly



**DELUXE ARTICULATED &  
ADJUSTABLE ROD HOLDER**  
With pyramidal base

# RTM



[www.RTMKAYAKS.com](http://www.RTMKAYAKS.com)



SHARE OUR EXPERIENCES WITH US



**ROTOMOD**

ZI JEAN MALEZE

47240 BON ENCONTRE - FRANCE

tel : +33 (0)5 53 98 53 98

[info@rotomod.com](mailto:info@rotomod.com)

[www.rotomod.com](http://www.rotomod.com)

